

## Mitsubishi Heavy Industries VRF with KNX, Serial, and IP support

### IN776MHI\*\*\*O000 GATEWAY

USER MANUAL  
Version 1.2.9  
Publication date 2024-04-22

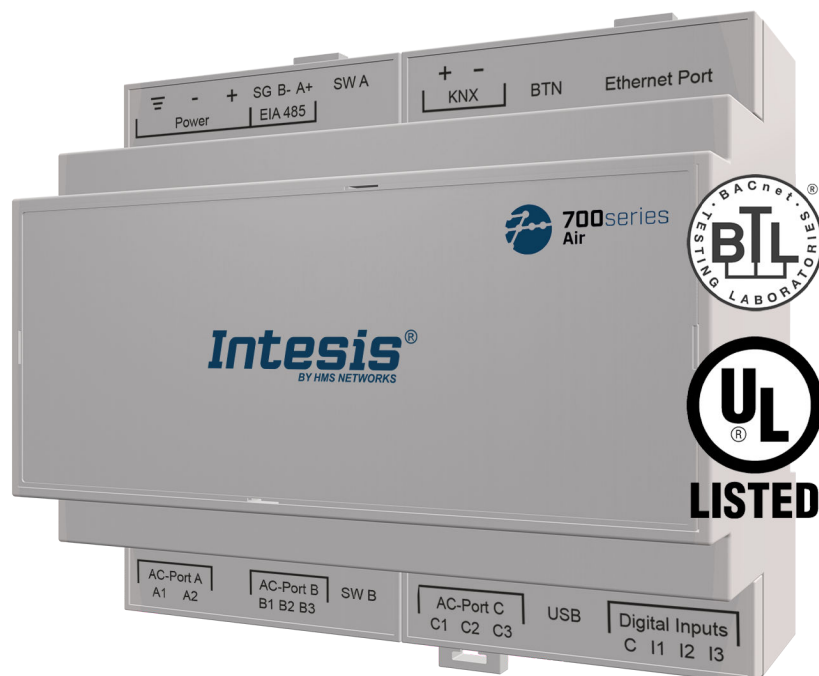

Copyright © 2023 Intesis

#### Disclaimer

The information in this document is for informational purposes only. Please inform HMS Networks of any inaccuracies or omissions found in this document. HMS Networks disclaims any responsibility or liability for any errors that may appear in this document.

HMS Networks reserves the right to modify its products in line with its policy of continuous product development. The information in this document shall therefore not be construed as a commitment on the part of HMS Networks and is subject to change without notice. HMS Networks makes no commitment to update or keep current the information in this document.

The data, examples and illustrations found in this document are included for illustrative purposes and are only intended to help improve understanding of the functionality and handling of the product. In view of the wide range of possible applications of the product, and because of the many variables and requirements associated with any particular implementation, HMS Networks cannot assume responsibility or liability for actual use based on the data, examples or illustrations included in this document nor for any damages incurred during installation of the product. Those responsible for the use of the product must acquire sufficient knowledge in order to ensure that the product is used correctly in their specific application and that the application meets all performance and safety requirements including any applicable laws, regulations, codes and standards. Further, HMS Networks will under no circumstances assume liability or responsibility for any problems that may arise as a result from the use of undocumented features or functional side effects found outside the documented scope of the product. The effects caused by any direct or indirect use of such aspects of the product are undefined and may include e.g. compatibility issues and stability issues.

# Table of Contents

<b>1. Description and Order Codes</b> .....	<b>1</b>
<b>2. Licensing</b> .....	<b>2</b>
<b>3. General Information</b> .....	<b>3</b>
3.1. Intended Use of the User Manual .....	3
3.2. General Safety Information .....	3
3.3. Admonition Messages and Symbols .....	3
<b>4. Overview</b> .....	<b>5</b>
4.1. Inside the Package .....	6
4.2. Main Features .....	6
4.3. Gateway General Functionality .....	7
<b>5. Hardware</b> .....	<b>8</b>
5.1. Mounting .....	8
5.2. Connection .....	10
5.2.1. Gateway Connectors .....	10
5.2.2. Connection Procedure for the AC Unit .....	12
5.2.3. Connection Procedure for Modbus .....	12
5.2.4. Connection Procedure for KNX .....	13
5.2.5. Connection Procedure for BACnet .....	14
5.2.6. Connection Procedure for Home Automation .....	15
5.2.7. Connection to a PC for Configuration .....	15
5.3. Gateway Layout .....	16
5.4. LED Indicators .....	17
5.5. DIP Switches .....	17
5.6. Push Button .....	18
5.7. Technical Specifications .....	19
5.8. Dimensions .....	20
<b>6. Available Applications</b> .....	<b>21</b>
6.1. Integration into Modbus Systems .....	21
6.1.1. Modbus Registers .....	21
6.2. Integration into KNX Systems .....	24
6.2.1. KNX .....	24
6.3. Integration into BACnet Systems .....	29
6.3.1. BACnet Objects .....	29
6.4. Integration into Home Automation Systems .....	32
6.4.1. Home Automation Signals .....	32
<b>7. Late Configuration: Change the Gateway's Protocol</b> .....	<b>33</b>
<b>8. Error Codes</b> .....	<b>34</b>

# 1. Description and Order Codes

## IN776MHI\*\*\*O000 Gateway.

Modbus®, KNX®, BACnet®, and Home Automation® gateway for Mitsubishi Heavy Industries® air conditioning systems.

ORDER CODE	LEGACY ORDER CODE
IN776MHI***O000 <sup>1</sup>	INMBSMHI048O000 INMBSMHI128O000 INKNXMHI048O000 INKNXMHI128O000
<sup>1</sup> *** stands for XXS, S, M, or L, depending on the license you have purchased. To know more, see <a href="#">Licensing (page 2)</a> .	



### NOTE

The order code may vary depending on the product seller and the buyer's location.

## 2. Licensing

Distribution license(s) for the IN776MHI\*\*\*O000 gateway:

Order Code	License	Maximum AC units	
		Indoor units	Outdoor units
IN776MHIXXSO000	XXS	4	12
IN776MHI00SO000	Small	16	12
IN776MHI00MO000	Medium	64	12
IN776MHI00LO000	Large	See note	See note



### NOTE

For IN776MHI00LO000, the maximum number of indoor units you can integrate depends on the number of integrated outdoor units. You can integrate up to 128 indoor units if you don't integrate any outdoor units. If you need to integrate outdoor units (up to 12), then the maximum number of indoor units you can integrate is 80. See the table below.

Max. indoor units	Max. outdoor units
128	0
80	12



### NOTE

The order code may vary depending on the product seller and the buyer's location.

## 3. General Information

### 3.1. Intended Use of the User Manual

This manual contains the main features of this Intesis gateway and the instructions for its appropriate installation, configuration, and operation.

The contents of this manual should be brought to the attention of any person who installs, configures, or operates this gateway or any associated equipment.

Keep this manual for future reference during the installation, configuration, and operation.

### 3.2. General Safety Information



#### IMPORTANT

Follow these instructions carefully. Improper work may seriously harm your health and damage the gateway and/or any other equipment connected to it.

Only technical personnel, following these instructions and the country legislation for installing electrical equipment, can install and manipulate this gateway.

Install this gateway indoors, in a restricted access location, avoiding exposure to direct solar radiation, water, high relative humidity, or dust.

All wires (for communication and power supply, if needed) must only be connected to networks with indoor wiring. All communication ports are considered for indoor use and must only be connected to SELV circuits.

Disconnect all systems from power before manipulating and connecting them to the gateway.

Use SELV-rated NEC class 2 or limited power source (LPS) power supply.

Use a circuit breaker before the power supply. Rating: 250 V, 6 A.

Supply always a correct voltage to power the gateway. See [Technical Specifications \(page 19\)](#).

Respect the expected polarity of power and communication cables when connecting them to the gateway.

### 3.3. Admonition Messages and Symbols



#### DANGER

Instructions that must be followed to avoid an imminently hazardous situation that, if not avoided, will result in death or severe injury.



#### WARNING

Instructions that must be followed to avoid a potentially hazardous situation that, if not avoided, could result in death or severe injury.



#### CAUTION

Instruction that must be followed to avoid a potentially hazardous situation that, if not avoided, could result in minor or moderate injury.



**IMPORTANT**

Instruction that must be followed to avoid a risk of reduced functionality and/or damage to the equipment or to avoid a network security risk.



**NOTE**

Additional information which may facilitate installation and/or operation.



**TIP**

Helpful advice and suggestions.



**NOTICE**

Remarkable Information.

## 4. Overview

This IN776MHI\*\*\*O000 gateway supports four applications.

Gateway's client interface	↔	Gateway's server interface
Mitsubishi Heavy Industries VRF HVAC systems	to	Modbus TCP and RTU
		KNX TP
		BACnet/IP or MS/TP
		Home Automation



### IMPORTANT

This document assumes that the user is familiar with these technologies.

Figure 1. Integration of Mitsubishi Heavy Industries AC systems into Modbus installations

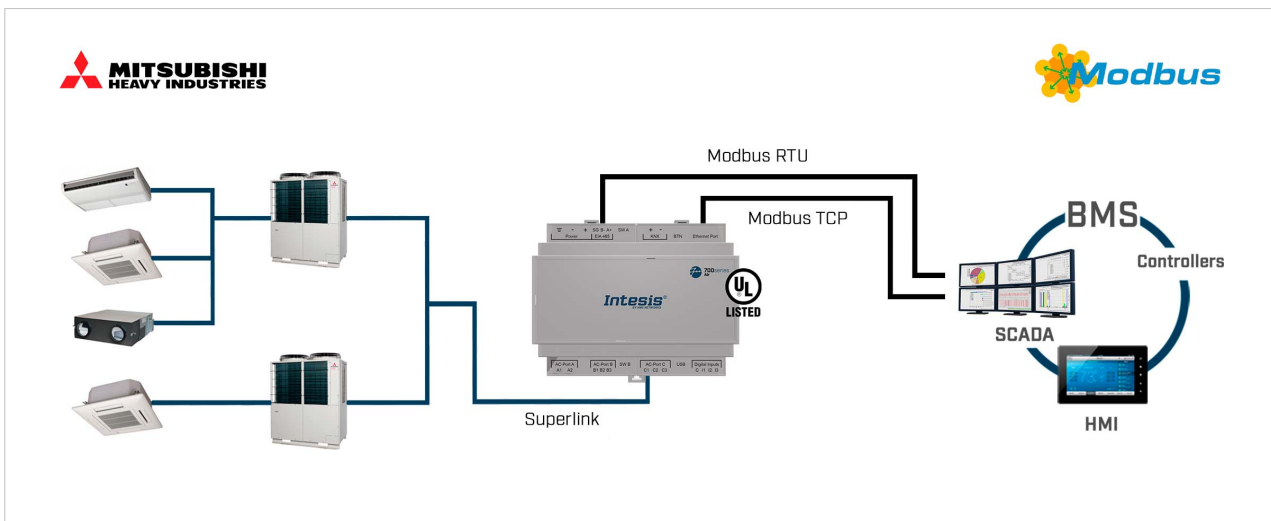

Figure 2. Integration of Mitsubishi Heavy Industries AC systems into KNX installations

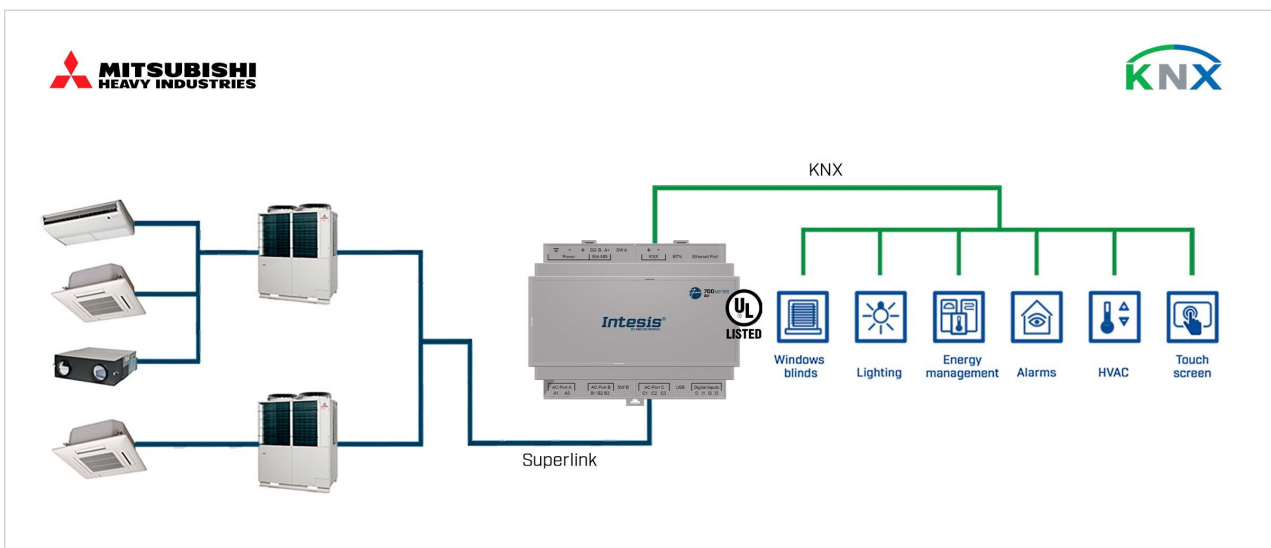

Figure 3. Integration of Mitsubishi Heavy Industries AC systems into BACnet installations

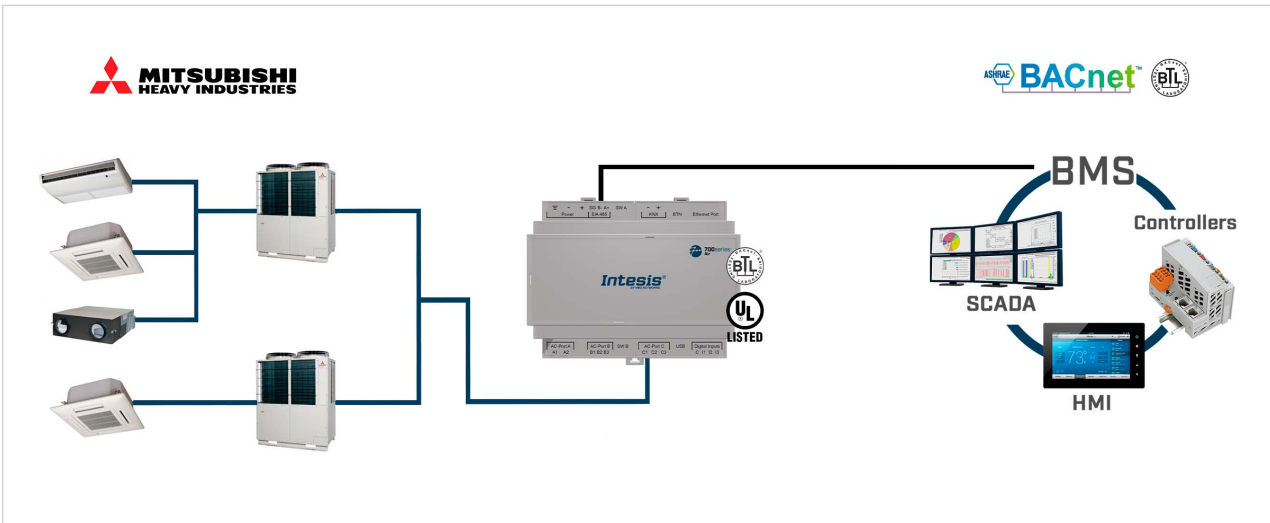
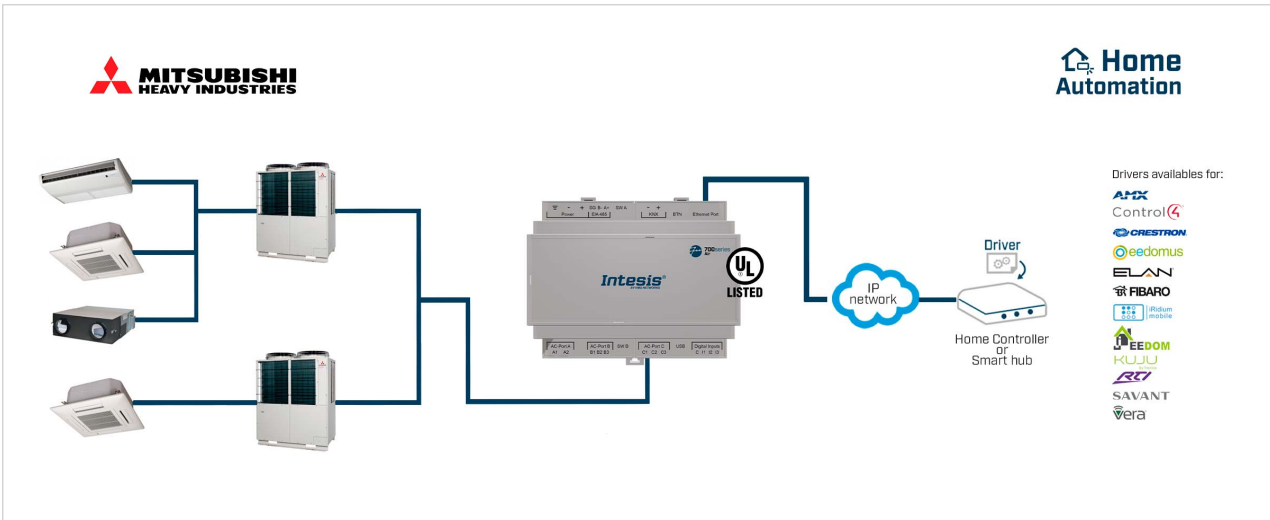

Figure 4. Integration of Mitsubishi Heavy Industries AC systems into Home Automation installations



## 4.1. Inside the Package

Items included:

- Intesis IN776MHI\*\*\*O000 Gateway
- USB Mini-B type to USB Type-A cable
- Installation Sheet

## 4.2. Main Features

- Several applications available: Configurable for BACnet/IP and MS/TP, Modbus TCP and RTU, KNX, and Home Automation communication protocols.
- Late configuration: Change between applications easily.
- Scan function: Find the devices connected to the air conditioning bus.
- Specific signals to monitor outdoor units.

- 2 x DIP switches for the EIA-485 connector termination and polarization configuration.
- 14 LEDs indicate the operating status for both the gateway and the communication bus.
- DIN rail and wall mounting case.
- Accredited with the main certifications for electronic equipment.
- Multiple ports for serial and TCP/IP communication:
  - Green pluggable terminal block for EIA-485 (3 poles)
  - Orange pluggable terminal block for KNX (2 poles)
  - Ethernet
  - Green pluggable terminal block for binary inputs (4 poles)
  - USB Mini-B type 2.0 port for connection to the PC
  - Green pluggable terminal block for AC connection (2 poles)
  - Green pluggable terminal block for AC connection (3 poles)
  - Green pluggable terminal block for AC connection (3 poles)

**NOTE**

Depending on the AC bus, some of these AC connection ports are not used. See [Gateway Connectors \(page 10\)](#).

### 4.3. Gateway General Functionality

With this Intesis IN776MHI\*\*\*0000 gateway, you can easily integrate Mitsubishi Heavy Industries systems into an installation based on Modbus TCP, Modbus RTU, KNX, BACnet/IP, BACnet MS/TP, or Home Automation. To do so, the gateway acts as a server device of the installation itself, accessing all signals from each air conditioner unit and controlling the whole AC network.

The gateway is continuously polling the AC network, storing in its memory the current status of every signal you want to track and serving this data to the installation when requested. Also, when a signal status changes, the gateway sends a write telegram to the installation, waits for the response, and performs the corresponding action.

A lack of response from a signal activates a communication error, allowing you to know which signal from which AC unit is not correctly working.

## 5. Hardware

### 5.1. Mounting

**IMPORTANT**

Before mounting, please ensure that the chosen installation place preserves the gateway from direct solar radiation, water, high relative humidity, or dust.

**IMPORTANT**

Maximum mounting height: below 2 meters (6.5 feet).

**NOTE**

Mount the gateway on a wall or over a DIN rail. We recommend the DIN rail mounting option, preferably inside a grounded metallic industrial cabinet.

**IMPORTANT**

Ensure the gateway has sufficient clearances for all connections when mounted. See [Dimensions \(page 20\)](#).

#### Wall mounting

1. Press the top side mobile clips in the rear panel until you hear a *click*.

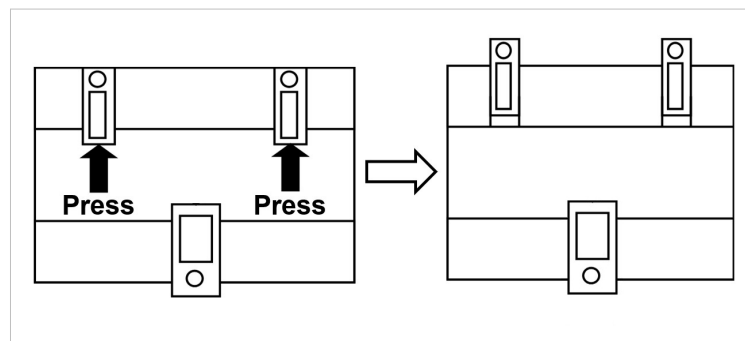

2. Use the clip holes to fix the gateway on the wall using screws.

**NOTE**

Use M3 screws, 25 mm (1") length.

3. Make sure the gateway is firmly fixed.

**DIN rail mounting**

1. Fit the gateway's top-side clips in the upper edge of the DIN rail.
2. Press the low side of the gateway gently to lock it in the DIN rail.
3. Make sure the gateway is firmly fixed.

**NOTE**

For some DIN rails, to complete step 2, you may need a small screwdriver or similar to pull the bottom clip down.

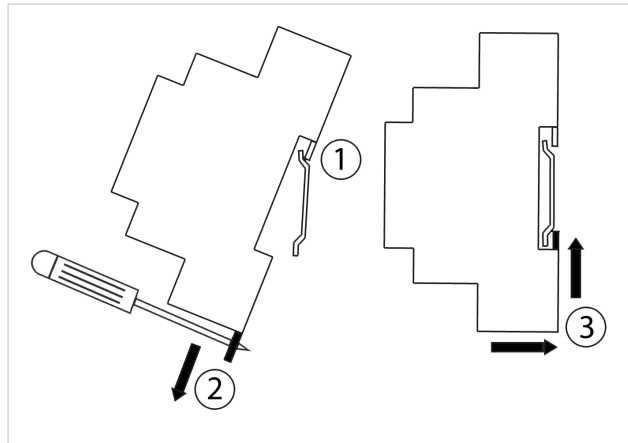

## 5.2. Connection



### CAUTION

Disconnect all systems from power before manipulating and connecting them to the gateway.



### IMPORTANT

Keep communication cables away from power and ground wires.

### 5.2.1. Gateway Connectors

Figure 5. Wiring diagram

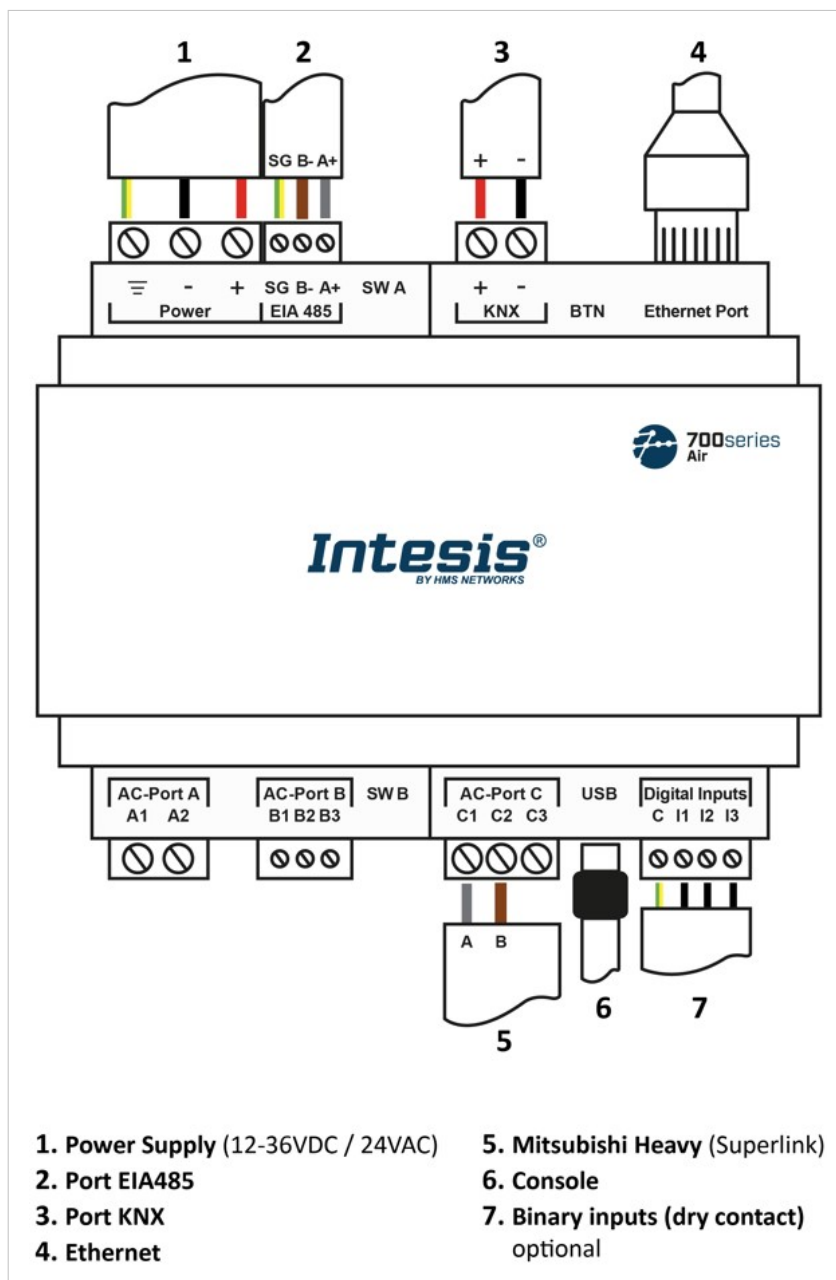

**Connectors' wiring:**



**IMPORTANT**

For all connectors, use solid or stranded wires (twisted or with ferrule).

Cross-section/gauge per terminal:

- One core: 0.2 .. 2.5 mm<sup>2</sup> / 24 .. 11 AWG
- Two cores: 0.2 .. 1.5 mm<sup>2</sup> / 24 .. 15 AWG
- Three cores: Not permitted



**NOTE**

To know more about each port's specifications, see [Technical Specifications \(page 19\)](#).

**Communication ports:**

PORT	USAGE	WIRING			
EIA-485	BACnet MS/TP and Modbus RTU	SG: Signal ground	B-	A+	
KNX	KNX bus	+		-	
Ethernet	<p><b>As an IP/TCP port:</b> BACnet/IP, Modbus TCP, and Home Automation</p> <p><b>As a console port:</b> Connection to a PC for configuration purposes</p>	Ethernet cable (CAT5 or higher) When using the building LAN, contact the network administrator and make sure traffic is allowed. When starting up the gateway for the first time, DHCP will be enabled for 30 seconds. After that time, the default IP 192.168.100.246 will be set.			
AC-Port A	<i>Not used</i>				
AC-Port B	<i>Not used</i>				
AC-Port C No polarity to observe	Mitsubishi Heavy Industries Superlink	C1: Superlink	C2: Superlink	C3: <i>Not used</i>	
USB	Connection to a PC for configuration purposes	USB Mini-B type			
Digital Inputs	Dry contact for input devices	C: Common	I1: Input 1	I2: Input 2	I3: Input 3

**Power supply:**

The power supply connector is a green pluggable terminal block (three poles) labeled as **Power**.

Apply the voltage within the admitted range and of enough power:

- **For DC:** 12 .. 36 VDC (±10%), Max: 250 mA
- **For AC:** 24 VAC (±10%), 50-60 Hz, Max: 127 mA

**Recommended voltage:** 24 VDC, Max: 127 mA



**IMPORTANT**

- **When using a DC power supply:** Respect the polarity labeled on the power connector for the positive and negative wires.
- **When using an AC power supply:** Ensure the same power supply is not powering any other device.

**IMPORTANT**

- Use SELV-rated NEC class 2 or limited power source (LPS) power supply.
- Respect the polarity.
- Connect the gateway's ground terminal  to the installation grounding.
- A wrong connection may cause earth loops and damage the Intesis gateway and/or other system equipment.

## 5.2.2. Connection Procedure for the AC Unit

Connect the Mitsubishi Heavy Industries air conditioning network bus (Superlink) to the gateway using the **C1** and **C2** poles of the **AC-Port C**.

**NOTE**

There is no polarity to observe.

**IMPORTANT**

This Intesis gateway supports VRF units with the Superlink-II version.<sup>1</sup>

**WIRING CONSIDERATIONS**

- Maximum wiring length: 1000 meters (0.75 miles).
- Loop wiring is not allowed.

**NOTE**

For the Mitsubishi Heavy Industries domestic series with an SC-BIKN-E connector, you need an SC-ADNA-E adapter (not included).

**NOTE**

See the [Wiring diagram \(page 10\)](#).

## 5.2.3. Connection Procedure for Modbus

**For Modbus TCP:**

Connect the Modbus TCP Ethernet cable to the gateway's **Ethernet Port**. The correct cable to use depends on where the gateway is connected:

- **Connecting directly to a Modbus TCP device:** use a crossover Ethernet UTP/FTP CAT5 or higher cable.
- **Connecting to a hub or switch of the LAN of the building:** use a straight Ethernet UTP/FTP CAT5 or higher cable.

**NOTE**

Some devices detect the difference automatically and adjust themselves.

<sup>1</sup>Superlink-II is also called New Superlink.

**NOTE**

When commissioning the gateway for the first time, DHCP will be enabled for 30 seconds. During that time, if there is a DHCP server, an IP address will be automatically assigned to the gateway. After that time, the default IP address 192.168.100.246 will be automatically set.

**IMPORTANT**

If communicating through the LAN of the building, contact the network administrator and make sure traffic on the used port is allowed through all LAN paths.

**For Modbus RTU:**

Connect the Modbus RTU communication cable to the gateway's **EIA-485** port.

**IMPORTANT**

Observe polarity.

**IMPORTANT**

Remember the characteristics of the standard EIA-485 bus:

- Maximum distance of 1200 meters (0.75 miles).
- Maximum of 32 devices connected to the bus.
- A 120 ohms ( $\Omega$ ) termination resistor is needed at each end of the bus. The gateway has an internal bus biasing circuit already incorporating the termination resistor. It can be enabled using the DIP switch block (**SW A**) dedicated to the **EIA-485** port:

**Position 1**

- ON: 120  $\Omega$  termination active.
- OFF: 120  $\Omega$  termination inactive.

**Positions 2 and 3**

- ON: Polarization active.
- OFF: Polarization inactive.

For further details, see [DIP Switches \(page 17\)](#).

**IMPORTANT**

When installing the gateway at the end of the bus with the termination resistor enabled, do not install an additional termination resistor at that end.

**NOTE**

See the [Wiring diagram \(page 10\)](#).

## 5.2.4. Connection Procedure for KNX

Connect the KNX TP communication cable to the gateway's **KNX port**.

**IMPORTANT**

Observe polarity.

**NOTE**

See the [Wiring diagram \(page 10\)](#).

## 5.2.5. Connection Procedure for BACnet

### For BACnet/IP:

Connect the BACnet/IP Ethernet cable to the gateway's **Ethernet Port**. The correct cable to use depends on where the gateway is connected:

- **Connecting directly to a BACnet/IP device:** use a crossover Ethernet UTP/FTP CAT5 or higher cable.
- **Connecting to a hub or switch of the LAN of the building:** use a straight Ethernet UTP/FTP CAT5 or higher cable.

**NOTE**

Some devices detect the difference automatically and adjust themselves.

**NOTE**

When commissioning the gateway for the first time, DHCP will be enabled for 30 seconds. During that time, if there is a DHCP server, an IP address will be automatically assigned to the gateway. After that time, the default IP address 192.168.100.246 will be automatically set.

**IMPORTANT**

If communicating through the LAN of the building, contact the network administrator and make sure traffic on the used port is allowed through all LAN paths.

### For BACnet MS/TP:

Connect the BACnet MS/TP communication cable to the gateway's **EIA-485** port.

**IMPORTANT**

Observe polarity.

**IMPORTANT**

Remember the characteristics of the standard EIA-485 bus:

- Maximum distance of 1200 meters (0.75 miles).
- Maximum of 32 devices connected to the bus.
- A termination resistor of 120 ohms ( $\Omega$ ) is needed at each end of the bus. The gateway has an internal bus biasing circuit already incorporating the termination resistor. It can be enabled using the DIP switch block dedicated to the EIA-485 port:

**Position 1**

- ON: 120  $\Omega$  termination active.
- OFF: 120  $\Omega$  termination inactive.

**Position 2 and 3**

- ON: Polarization active.
- OFF: Polarization inactive.

For further details, see [DIP Switches \(page 17\)](#).

**IMPORTANT**

When installing the gateway at the end of the bus with the termination resistor enabled, do not install an additional termination resistor at that end.

**NOTE**

See the [Wiring diagram \(page 10\)](#).

## 5.2.6. Connection Procedure for Home Automation

Connect the Home Automation Ethernet cable to the gateway's **Ethernet Port**. The correct cable to use depends on where the gateway is connected:

- **Connecting directly to a Home Automation device:** use a crossover Ethernet UTP/FTP CAT5 or higher cable.
- **Connecting to a hub or switch of the LAN of the building:** use a straight Ethernet UTP/FTP CAT5 or higher cable.

**NOTE**

When commissioning the gateway for the first time, DHCP will be enabled for 30 seconds. During that time, if there is a DHCP server, an IP address will be automatically assigned to the gateway. After that time, the default IP address 192.168.100.246 will be automatically set.

**IMPORTANT**

If communicating through the LAN of the building, contact the network administrator and make sure traffic on the used port is allowed through all LAN paths.

**NOTE**

See the [Wiring diagram \(page 10\)](#).

## 5.2.7. Connection to a PC for Configuration

Use the supplied USB Mini-B type to USB Type-A cable to connect the gateway through its **Console** port to a PC to configure it with Intesis MAPS.

**NOTE**

Find all you need to know about the gateway configuration and Intesis MAPS in the [Intesis MAPS Configuration Guide for IN776MHI\\*\\*\\*O000](#).

**NOTE**

See the [Wiring diagram \(page 10\)](#).

### 5.3. Gateway Layout

Figure 6. Disposition of hardware elements in the gateway

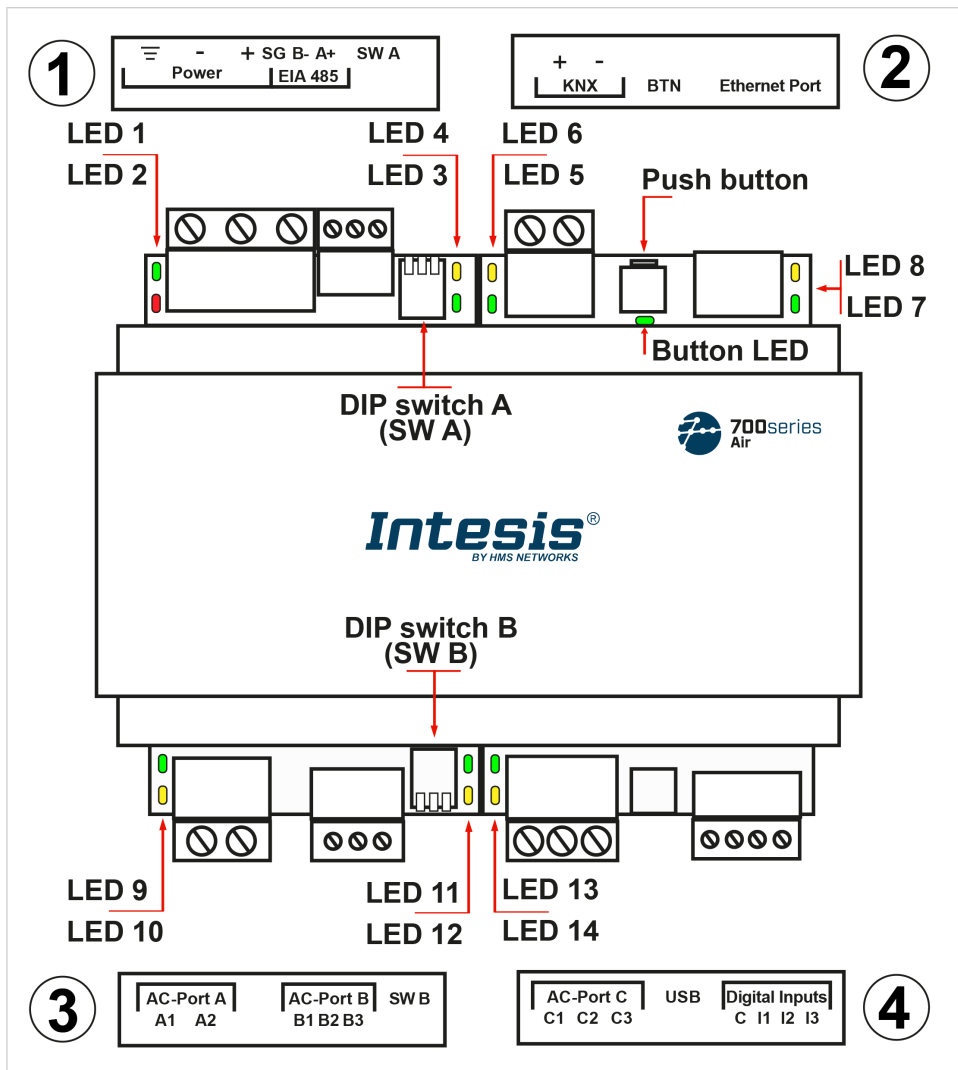

Plastic covers numbered in the image as ①, ②, ③, and ④ can be easily disassembled.

The following sections explain each element in more detail: LEDs, DIP switches, and the push button.

## 5.4. LED Indicators

Table 1. LEDs location and behavior

Cover	LED	Color	Description
<b>Top side</b>			
Under frontal cover ①	LED 1 (PWR)	Green	Power on (not programmable)
	LED 2 (ERR)	Red	Blinking: Hardware error
	LED 3	Green	485 Tx (RS485 for BACnet or Modbus)
	LED 4	Yellow	485 Rx (RS485 for BACnet or Modbus)
Under frontal cover ②	LED 5	Green	KNX Port Tx
	LED 6	Yellow	KNX Port Rx
	BUTTON LED	Green	<b>KNX:</b> Programming mode on <b>BACnet:</b> BACnet link established <b>Modbus and Home Automation:</b> Not used
	LED 7	Green	Ethernet link established
	LED 8	Yellow	Ethernet speed
<b>Bottom side</b>			
Under frontal cover ③	LED 9	Green	AC-Port A Tx (HBS)
	LED 10	Yellow	AC-Port A Rx (HBS)
	LED 11	Green	AC-Port B Tx (RS485)
	LED 12	Yellow	AC-Port B Rx (RS485)
Under frontal cover ④	LED 13	Green	AC-Port C Tx (UFO-SLQ): It shows Superlink activity
	LED 14	Yellow	AC-Port C Rx (UFO-SLQ): It show Superlink activity



### NOTE

LEDs are hidden behind the four frontal labeled covers (see the figure [Disposition of hardware elements in the gateway \(page 16\)](#)). These covers are assembled by pressure, so you just need to pull them to remove them.

## 5.5. DIP Switches

The gateway has two DIP switches (see the figure [Disposition of hardware elements in the gateway \(page 16\)](#)):

- DIP switch A (SW A)
- DIP switch B (SW B)

Each DIP switch is dedicated to a 485 port, and its function is to activate or deactivate the termination resistor (position 1) and the polarization (positions 2 and 3) of each port:

Position			Description
1	2	3	
↑	X	X	120 Ω termination active
↓	X	X	120 Ω termination inactive (default position)
X	↑	↑	Polarization active (default position)
X	↓	↓	Polarization inactive

## 5.6. Push Button

Find the push button at the top side, between the KNX and the Ethernet connectors (see the figure [Disposition of hardware elements in the gateway \(page 16\)](#)).

**NOTE**

The button is hidden and only accessible using a thin object like a paper clip.

Common functionality:

**Reset factory settings**

1. Push the button.
2. Power on the gateway.
3. Wait four seconds.
4. Release the button.

Functionalities depending on the current project:

**BACnet**

- Push the button to send an I-Am message to all BACnet ports.

**KNX**

- Push the button to switch between normal mode and programming mode.

## 5.7. Technical Specifications

<b>Housing</b>	Plastic, type PC (UL 94 V-0). Color: Light Grey. RAL 7035 Net dimensions (dxwxh): Millimeters: 90 x 106 x 58 mm / Inches: 3.5 x 4.2 x 2.3"	
<b>Mounting</b>	Wall: Use M3 25 mm (1") length screws. Secure mounting: below 2 meters (6 feet) DIN rail (recommended mounting) EN60715 TH35	
<b>Wires (for power supply and low-voltage signals)</b>	Wire cross-section/gauge per terminal: One core: 0.2 .. 2.5 mm <sup>2</sup> (24 .. 14 AWG) Two cores: 0.2 to 1.5 mm <sup>2</sup> (24 .. 16 AWG) Three cores: Not permitted Use solid or stranded wires (twisted or with ferrule). For distances longer than 3.05 meters (10 feet), use class 2 cables	
<b>Power</b>	1 x Green pluggable terminal block (3 poles) 12 to 36 VDC +/-10%, Max.: 250 mA 24 VAC +/-10% 50-60 Hz, Max.: 127 mA Recommended: 24 VDC	
<b>Ethernet</b>	1 x Ethernet 10/100 Mbps RJ45	
<b>Port EIA 485</b>	1 x Green pluggable terminal block (3 poles) SGND (Reference ground or shield) 1500 VDC isolation from other ports	
<b>Port KNX</b>	1 x Orange pluggable terminal block (2 poles): A, B	
<b>AC Ports</b>	AC-Port A (serial, 2 poles): Not used AC-Port B (serial, 3 poles): Not used AC-Port C: (serial, 3 poles): AC bus connection (Superlink)	
<b>LEDs</b>	2 x Run (Power/Error) 2 x Port EIA-485 TX/RX 2 x Port KNX TX/TR 1 x Button indicator	2 x Ethernet Link/Speed 2 x AC-Port A TX/RX 2 x AC-Port B TX/RX 2 x AC-Port C TX/RX
<b>Binary inputs</b>	1 x Green pluggable terminal block (4 poles) I1, I2, I3, and Common 1500 VDC isolation from other ports	
<b>Console port</b>	USB Mini-B type 2.0 compliant 1500 VDC isolation	
<b>SW A SW B</b>	2 x DIP switch blocks for EIA-485 serial port configuration: Position 1: On: 120 Ω termination active Off: 120 Ω termination inactive Position 2 and 3: On: Polarization active Off: Polarization inactive	
<b>Push button</b>	1 x Push button Factory reset I-Am message (for BACnet only) Normal mode/programming mode switch (for KNX only)	
<b>Operational temperature</b>	Celsius: 0 .. 60°C Fahrenheit: 32 .. 140°F	
<b>Operational humidity</b>	5 to 95%. No condensation	
<b>Protection</b>	IP20 (IEC60529)	

## 5.8. Dimensions

- **Net dimensions (DxWxH)**

Millimeters: 90 x 106 x 58 mm

Inches: 3.5 x 4.2 x 2.3"



### IMPORTANT

Leave enough clear space to wire the gateway easily and for the subsequent manipulation of elements.

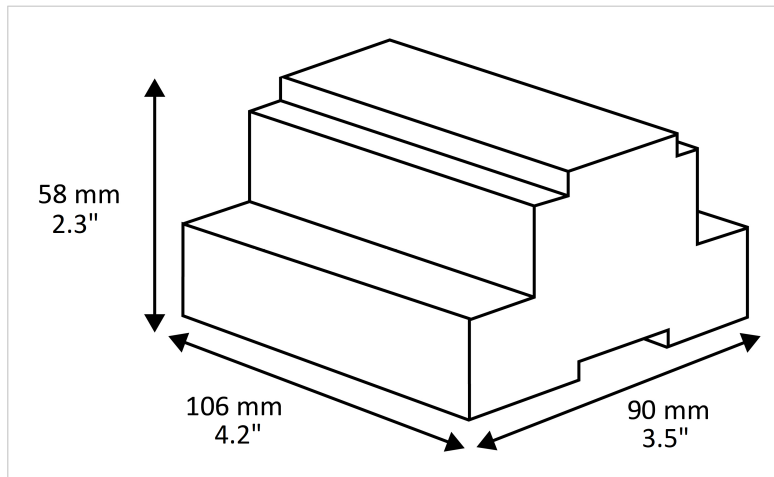

## 6. Available Applications

### 6.1. Integration into Modbus Systems

#### 6.1.1. Modbus Registers



##### NOTICE

This part is common for Modbus RTU and TCP.

##### Functions to read Modbus registers:

- 03 Read Holding Registers.
- 04 Read Input Registers.

##### Function to write Modbus registers:

- 06 Single Holding Registers.

Modbus register contents are expressed in most significant bit (MSB) .. less significant bit (LSB).

The following tables list all available Modbus registers for the gateway.



##### NOTICE

Read/write parameter terminology:

- **R**: Read-only register.
- **W**: Write-only register.
- **RW**: Read and write register.
- **T**: Trigger-only register

Table 2. Global registers

Register name	Possible values	Modbus address	R/W
Gateway Communication Status	0: No Error 1: Failure	2995	R
On/Off (all the units)	0: Off 1: On	2996	R, W
Operation Mode (all the units)	0: Cool 1: Heat 2: Fan 3: Auto 4: Dry	2997	R, W
Setpoint (all the units) (x10)	Celsius: 16 .. 30°C Fahrenheit: 60 .. 86°F	2998	R, W
Fan Speed (all the units)	0: Low 1: Medium 2: High 3: Powerful	2999	R, W
Remote Lock (all the units)	1: Lock 0: Unlock	3000	R, W

Table 3. Outdoor unit registers

Register name	Possible values	Modbus address	R/W
OU Compressor 1 Frequency	0 .. 255 Hz	(OU address[0..127] × 20) + 4000 + 1	R
OU Compressor 2 Frequency	0 .. 255 Hz	(OU address[0..127] × 20) + 4000 + 2	R
OU Heat Exchange low 1 temperature (x10)	°C / °F	(OU address[0..127] × 20) + 4000 + 3	R
OU Heat Exchange low 2 temperature (x10)	°C / °F	(OU address[0..127] × 20) + 4000 + 4	R
OU Heat Exchange low 3 temperature (x10)	°C / °F	(OU address[0..127] × 20) + 4000 + 5	R
OU Heat Exchange low 4 temperature (x10)	°C / °F	(OU address[0..127] × 20) + 4000 + 6	R
OU Heat exchange high 1 temperature (x10)	°C / °F	(OU address[0..127] × 20) + 4000 + 7	R
OU Heat exchange high 2 temperature (x10)	°C / °F	(OU address[0..127] × 20) + 4000 + 8	R
OU Heat exchange high 3 temperature (x10)	°C / °F	(OU address[0..127] × 20) + 4000 + 9	R
OU Heat exchange high 4 temperature (x10)	°C / °F	(OU address[0..127] × 20) + 4000 + 10	R
OU Unit temperature (x10)	°C / °F	(OU address[0..127] × 20) + 4000 + 11	R
OU Discharge pipe temperature 1 (x10)	°C / °F	(OU address[0..127] × 20) + 4000 + 12	R
OU Discharge pipe temperature 2 (x10)	°C / °F	(OU address[0..127] × 20) + 4000 + 13	R
OU Crankcase 1 temperature (x10)	°C / °F	(OU address[0..127] × 20) + 4000 + 14	R
OU Crankcase 2 temperature (x10)	°C / °F	(OU address[0..127] × 20) + 4000 + 15	R
OU Compressor current 1 (x10)	Amperes	(OU address[0..127] × 20) + 4000 + 16	R
OU Compressor current 2 (x10)	Amperes	(OU address[0..127] × 20) + 4000 + 17	R
OU High pressure (x100)	MPa	(OU address[0..127] × 20) + 4000 + 18	R
OU Low pressure (x100)	MPa	(OU address[0..127] × 20) + 4000 + 19	R

Table 4. Indoor unit registers

Register name	Possible values	Modbus address	R/W
Communication Status	0: No Error 1: Error	(IU address[0..127] × 20) + 1	R
On/Off	0: Off 1: On	(IU address[0..127] × 20) + 2	R, W
Operation Mode	0: Cool 1: Heat 2: Fan 3: Auto 4: Dry	(IU address[0..127] × 20) + 3	R, W
Temperature Setpoint (x10)	Celsius: 16 .. 30°C Fahrenheit: 60 .. 86°F	(IU address[0..127] × 20) + 4	R, W
Fan Speed	0: Low 1: Medium 2: High 3: Powerful	(IU address[0..127] × 20) + 5	R, W
Remote Lock	0: Unlock 1: Lock	(IU address[0..127] × 20) + 6	R, W

Louver / Vane Position	0: Swing 1: Position 1 2: Position 2 3: Position 3 4: Position 4	(IU address[0..127] × 20) + 7	R, W
Room Temperature (x10)	Celsius: 0 .. 30°C Fahrenheit: 32 .. 86°F	(IU address[0..127] × 20) + 8	R
Filter Sign Status	0: Off 1: On	(IU address[0..127] × 20) + 9	R
Unit Error code	0: No Error X (1.. 255): Error	(IU address[0..127] × 20) + 10	R
Compressor Status	0: Off 1: On	(IU address[0..127] × 20) + 11	R
Filter Sign Reset	1: Reset	(IU address[0..127] × 20) + 12	W
RC Error Reset	1-Reset	(IU address[0..127] × 20) + 13	W
Thermo On/Off	0: Off 1: On	(IU address[0..127] × 20) + 14	R
Expansion valve opening pulse status	000 .. 999	(IU address[0..127] × 20) + 15	R
Decision frequency status	0 .. 255 Hz	(IU address[0..127] × 20) + 16	R
Demand frequency status	0 .. 255 Hz	(IU address[0..127] × 20) + 17	R
Heat Exchange low 1 temperature (x10)	°C / °F	(IU address[0..127] × 20) + 18	R
Heat Exchange low 2 temperature (x10)	°C / °F	(IU address[0..127] × 20) + 19	R
Heat Exchange low 3 temperature (x10)	°C / °F	(IU address[0..127] × 20) + 20	R
Consumption Yesterday (Wh)	Wh/KWh	(IU address[0..127] × 20) + 6001	R
Consumption Today (Wh)	Wh/KWh	(IU address[0..127] × 20) + 6003	R
Consumption Total (Wh)	Wh/KWh	(IU address[0..127] × 20) + 6005	R
Consumption Yesterday Heat (Wh)	Wh/KWh	(IU address[0..127] × 20) + 6007	R
Consumption Today Heat (Wh)	Wh/KWh	(IU address[0..127] × 20) + 6009	R
Consumption Total Heat (Wh)	Wh/KWh	(IU address[0..127] × 20) + 6011	R
Consumption Yesterday Cool (Wh)	Wh/KWh	(IU address[0..127] × 20) + 6013	R
Consumption Today Cool (Wh)	Wh/KWh	(IU address[0..127] × 20) + 6015	R
Consumption Total Cool (Wh)	Wh/KWh	(IU address[0..127] × 20) + 6017	R

## 6.2. Integration into KNX Systems

### 6.2.1. KNX

The following tables list all available KNX signals for this gateway.



#### NOTE

**Physical Address:** The gateway supports (P/S) and (P/I/S) format levels.



#### NOTICE

Communication object flags:

- **Ri (Read on initialization):** The gateway requests this signal's updated data after an initialization instead of waiting for a change in the signal.
- **R:** The KNX system can read this signal.
- **W:** The KNX system can write this signal.
- **T:** The KNX system receives a telegram when this signal changes its value.
- **U:** This signal's data is updated after a reboot of either the gateway or the bus.

Table 5. Global signals

Description	Function	DPT	Flags
Status_Gateway Communication Status	0: No Error 1: Failure	1.005-DPT_Alarm (1bit)	R, T
Control_On/Off (all units)	0: Off 1: On	1.001-DPT_Switch (1bit)	W
Control_Operating Mode (all units)	0: Auto 1: Heat 3: Cool 9: Fan 14: Dry	20.105-DPT_HVACContrMode (1byte)	W
Control_Operating Mode (all units)	0: Auto 1: Heat 2: Dry 3: Fan 4: Cool	5.x (1byte)	W
Control_Operating Mode (all units)	0: Cool 1: Heat 2: Fan 3: Dry 4: Auto	5.x (1byte)	W
Control_Fan Speed (all units)	0: Low 1: Medium 2: High 3: Powerful	5.x (1byte)	W
Control_Setpoint (all the units)	Celsius: 16 .. 30°C Fahrenheit: 60 .. 86°F	9.001/9.027-DPT_Value_Temp (2byte)	W
Control_Remote Lock/Unlock (all the units)	0: Unlock 1: Lock	1.002 DPT_Bool (1bit)	W

Table 6. Outdoor units

Description	Function	DPT	Flags
Status_OU Compressor 1 Frequency	Hz	14.033-DPT_Value_Frequency (4byte)	R, T
Status_OU Compressor 2 Frequency	Hz	14.033-DPT_Value_Frequency (4byte)	R, T
Status_OU Heat Exchange low 1 temperature	°C / °F	9.001/9.027-DPT_Value_Temp (2byte)	R, T
Status_OU Heat Exchange low 2 temperature	°C / °F	9.001/9.027-DPT_Value_Temp (2byte)	R, T
Status_OU Heat Exchange low 3 temperature	°C / °F	9.001/9.027-DPT_Value_Temp (2byte)	R, T
Status_OU Heat Exchange low 4 temperature	°C / °F	9.001/9.027-DPT_Value_Temp (2byte)	R, T
Status_OU Heat Exchange high 1 temperature	°C / °F	9.001/9.027-DPT_Value_Temp (2byte)	R, T
Status_OU Heat Exchange high 2 temperature	°C / °F	9.001/9.027-DPT_Value_Temp (2byte)	R, T
Status_OU Heat Exchange high 3 temperature	°C / °F	9.001/9.027-DPT_Value_Temp (2byte)	R, T
Status_OU Heat Exchange high 4 temperature	°C / °F	9.001/9.027-DPT_Value_Temp (2byte)	R, T
Status_OU Unit temperature	°C / °F	9.001/9.027-DPT_Value_Temp (2byte)	R, T
Status_OU Discharge pipe temperature 1	°C / °F	9.001/9.027-DPT_Value_Temp (2byte)	R, T
Status_OU Discharge pipe temperature 2	°C / °F	9.001/9.027-DPT_Value_Temp (2byte)	R, T
Status_OU Crankcase temperature 1	°C / °F	9.001/9.027-DPT_Value_Temp (2byte)	R, T
Status_OU Crankcase temperature 2	°C / °F	9.001/9.027-DPT_Value_Temp (2byte)	R, T
Status_OU Compressor current 1	Amperes	14.019-DPT_Value_Electric_Current (4byte)	R, T
Status_OU Compressor current 2	Amperes	14.019-DPT_Value_Electric_Current (4byte)	R, T
Status_OU High pressure	MPa	14.058-DPT_Value_Pressure (4byte)	R, T
Status_OU Low pressure	MPa	14.058-DPT_Value_Pressure (4byte)	R, T

Table 7. Indoor units

Description	Function	DPT	Flags
Status_CommError	0: No error 1: Error	1.005-DPT_Alarm (1bit)	R, T
Control_On/Off	0: Off 1: On	1.001-DPT_Switch (1bit)	Ri, W, U
Status_On/Off	0: Off 1: On	1.001-DPT_Switch (1bit)	R, T
Control_Operation mode	0: Auto 1: Heat 3: Cool 9: Fan 14: Dry	20.105-DPT_HVACContrMode (1byte)	Ri, W, U
Status_Operation mode	0: Auto 1: Heat 3: Cool 9: Fan 14: Dry	20.105-DPT_HVACContrMode (1byte)	R, T

Description	Function	DPT	Flags
Control_Operation mode	0: Auto 1: Heat 2: Dry 3: Fan 4: Cool	5.x (1byte)	Ri, W, U
Status_Operation mode	0: Auto 1: Heat 2: Dry 3: Fan 4: Cool	5.x (1byte)	R, T
Control_Mode Cool/Heat	0: Cool 1: Heat	1.100-DPT_Heat/Cool (1bit)	Ri, W, U
Status_Mode Cool/Heat	0: Cool 1: Heat	1.100-DPT_Heat/Cool (1bit)	R, T
Control_Auto mode	1: Set auto mode	1.001-DPT_Switch (1bit)	Ri, W, U
Status_Auto mode	1: Auto mode active 0: Auto mode not active	1.001-DPT_Switch (1bit)	R, T
Control_Heat mode	1: Set heat mode	1.001-DPT_Switch (1bit)	Ri, W, U
Status_Heat mode	1: Heat mode active 0: Heat mode not active	1.001-DPT_Switch (1bit)	R, T
Control_Cool mode	1: Set cool mode	1.001-DPT_Switch (1bit)	Ri, W, U
Status_Cool mode	1: Cool mode active 0: Cool mode not active	1.001-DPT_Switch (1bit)	R, T
Control_Fan mode	1: Set fan mode	1.001-DPT_Switch (1bit)	Ri, W, U
Status_Fan mode	1: Fan mode active 0: Fan mode not active	1.001-DPT_Switch (1bit)	R, T
Control_Dry mode	1: Set dry mode	1.001-DPT_Switch (1bit)	Ri, W, U
Status_Dry mode	1: Dry mode active 0: Dry mode not active	1.001-DPT_Switch (1bit)	R, T
Control_Temperature setpoint	Celsius: 16 .. 30°C Fahrenheit: 60 .. 86°F	9.001/9.027-DPT_Value_Temp (2byte)	Ri, W, U
Status_Temperature setpoint	Celsius: 16 .. 30°C Fahrenheit: 60 .. 86°F	9.001/9.027-DPT_Value_Temp (2byte)	R, T
Control_Fan speed enumerated	0: Low 1: Medium 2: High 3: Powerful	5.x (1byte)	Ri, W, U
Status_Fan speed enumerated	0: Low 1: Medium 2: High 3: Powerful	5.x (1byte)	R, T
Control_Fan speed scaling	Thresholds: 0 .. 24% 25 .. 49% 50 .. 74% 75 .. 100%	5.001-DPT_Scaling (1byte)	Ri, W, U

Description	Function	DPT	Flags
Status_Fan speed scaling	Thresholds: 25% 50% 75% 100%	5.001-DPT_Scaling (1byte)	R, T
Control_Fan speed low	1: Set fan speed low	1.001-DPT_Switch (1bit)	Ri, W, U
Status_Fan speed low	1: Speed low active 0: Speed low not active	1.001-DPT_Switch (1bit)	R, T
Control_Fan speed medium	1: Set fan speed medium	1.001-DPT_Switch (1bit)	Ri, W, U
Status_Fan speed medium	1: Speed medium active 0: Speed medium not active	1.001-DPT_Switch (1bit)	R, T
Control_Fan speed high	1: Set fan speed high	1.001-DPT_Switch (1bit)	Ri, W, U
Status_Fan speed high	1: Speed high active 0: Speed high not active	1.001-DPT_Switch (1bit)	R, T
Control_Fan speed powerful	1: Set fan speed powerful	1.001-DPT_Switch (1bit)	Ri, W, U
Status_Fan speed powerful	1: Speed powerful active 0: Speed powerful not active	1.001-DPT_Switch (1bit)	R, T
Control_Louver / Vane Position enumerated	1 .. 4: Position1.. Position4	5.x (1byte)	Ri, W, U
Status_Louver / Vane Position enumerated	1.. 4: Position1.. Position4	5.x (1byte)	R, T
Control_Louver / Vane Position scaling	Thresholds: 0 .. 24% 25 .. 49% 50 .. 74% 75 .. 100%	5.001-DPT_Scaling (1byte)	Ri, W, U
Status_Louver / Vane Position scaling	Thresholds: 25% 50% 75% 100%	5.001-DPT_Scaling (1byte)	R, T
Control_Vanes position-1	1: Set position-1 vanes	1.001-DPT_Switch (1bit)	Ri, W, U
Status_Vanes position-1	1: Vanes position-1 active 0: Vanes position-1 not active	1.001-DPT_Switch (1bit)	R, T
Control_Vanes position-2	1: Set position-2 vanes	1.001-DPT_Switch (1bit)	Ri, W, U
Status_Vanes position-2	1: Vanes position-2 active 0: Vanes position-2 not active	1.001-DPT_Switch (1bit)	R, T
Control_Vanes position-3	1: Set position-3 vanes	1.001-DPT_Switch (1bit)	Ri, W, U
Status_Vanes position-3	1: Vanes position-3 active 0: Vanes position-3 not active	1.001-DPT_Switch (1bit)	R, T
Control_Vanes position-4	1: Set position-4 vanes	1.001-DPT_Switch (1bit)	Ri, W, U
Status_Vanes position-4	1: Vanes position-4 active 0: Vanes position-4 not active	1.001-DPT_Switch (1bit)	R, T
Control_Vanes position swing	0: Swing off 1: Swing on	1.001-DPT_Switch (1bit)	Ri, W, U
Status_Vanes position swing	0: Swing off 1: Swing on	1.001-DPT_Switch (1bit)	R, T

Description	Function	DPT	Flags
Status_AC ambient temperature	Celsius: 0 .. 30 °C Fahrenheit: 32 .. 86°F	9.001/9.027-DPT_Value_Temp (2byte)	R, T
Control_KNX ambient temperature	°C / °F	9.001/9.027-DPT_Value_Temp (2byte)	Ri, W, U
Status_FilterSign	0: Normal 1: Alarm	1.005-DPT_Alarm (1bit)	R, T
Control_FilterReset	0: No reset 1: Reset	1.015-DPT_Reset (1bit)	Ri, W, U
Status_Unit error code	0: No Error 1 .. 255: Error	8.x (2 byte)	R, T
Status_Compressor status	0: Off 1: On	1.001-DPT_Switch (1bit)	R, T
Control_RC Error Reset	0: No reset 1: Reset	1.015-DPT_Reset (1bit)	Ri, W, U
Status_Thermo On/Off	0: Off 1: On	1.001-DPT_Switch (1bit)	R, T
Status_Expansion valve opening pulse status	000 .. 999	8.x (2 byte)	R, T
Status_Decision frequency status	0 .. 255 Hz	14.033-DPT_Value_Frequency (4byte)	R, T
Status_Demand frequency status	0 .. 255 Hz	14.033-DPT_Value_Frequency (4byte)	R, T
Status_Heat Exchange low 1 temperature	°C / °F	9.001/9.027-DPT_Value_Temp (2byte)	R, T
Status_Heat Exchange low 2 temperature	°C / °F	9.001/9.027-DPT_Value_Temp (2byte)	R, T
Status_Heat Exchange low 3 temperature	°C / °F	9.001/9.027-DPT_Value_Temp (2byte)	R, T
Status_Consumption Yesterday Heat	Wh/KWh	13.010: active energy (Wh)	R, T
Status_Consumption Today Heat	Wh/KWh	13.010: active energy (Wh)	R, T
Status_Consumption Total Heat	Wh/KWh	13.010: active energy (Wh)	R, T
Status_Consumption Yesterday Cool	Wh/KWh	13.010: active energy (Wh)	R, T
Status_Consumption Today Cool	Wh/KWh	13.010: active energy (Wh)	R, T
Status_Consumption Total Cool	Wh/KWh	13.010: active energy (Wh)	R, T

**NOTE**

The default unit for the consumption signals is Wh, but you can set it in KWh instead. If so, the DPT number changes from 13.010 to 13.013.

## 6.3. Integration into BACnet Systems



### NOTICE

You can see the Protocol Implementation Conformance Statement (PICS) document on <https://www.intesis.com/docs/bacnet-client-pic-statement-776>

### 6.3.1. BACnet Objects



### NOTICE

This part is common for BACnet MS/TP and BACnet/IP.

#### Input object types:

- Binary input

#### Output object types:

- Binary output
- Multistate output
- Analog output

The following tables list all available BACnet objects for this gateway.

Table 8. Global signals

Object name	Possible values	Type	Object instance
Gateway Communication Status	0: No error 1: Error	3-Binary Input	15000 + 0
On/Off (all units)	0: Off 1: On	4-Binary Output	15000 + 0
Mode (all units)	1: Heat 2: Cool 3: Fan 4: Dry 5: Auto	14-Multistate Output	15000 + 0
Setpoint	°C / °F	1-Analog Output	15000 + 0
FanSpeed (all units)	1: Low 2: Medium 3: High 4: Powerful	14-Multistate Output	15000 + 1
Remote Lock	0: Unlock 1: Lock	4-Binary Output	15000 + 1

Table 9. Outdoor units

Object name	Possible values	Type	Object instance
OUXX_Compressor 1 Frequency	Hz	0-Analog Input	(OU[1..12] × 20) + 10000 + 0
OUXX_Compressor 2 Frequency	Hz	0-Analog Input	(OU[1..12] × 20) + 10000 + 1
OUXX_Heat Exchange low 1 temperature	°C / °F	0-Analog Input	(OU[1..12] × 20) + 10000 + 2
OUXX_Heat Exchange low 2 temperature	°C / °F	0-Analog Input	(OU[1..12] × 20) + 10000 + 3
OUXX_Heat Exchange low 3 temperature	°C / °F	0-Analog Input	(OU[1..12] × 20) + 10000 + 4
OUXX_Heat Exchange low 4 temperature	°C / °F	0-Analog Input	(OU[1..12] × 20) + 10000 + 5
OUXX_Heat exchange high 1 temperature	°C / °F	0-Analog Input	(OU[1..12] × 20) + 10000 + 6

Object name	Possible values	Type	Object instance
OUIX_Heat exchange high 2 temperature	°C / °F	0-Analog Input	(OU[1..12] × 20) + 10000 + 7
OUIX_Heat exchange high 3 temperature	°C / °F	0-Analog Input	(OU[1..12] × 20) + 10000 + 8
OUIX_Heat exchange high 4 temperature	°C / °F	0-Analog Input	(OU[1..12] × 20) + 10000 + 9
OUIX_Unit temperature	°C / °F	0-Analog Input	(OU[1..12] × 20) + 10000 + 10
OUIX_Discharge pipe 1 temperature	°C / °F	0-Analog Input	(OU[1..12] × 20) + 10000 + 11
OUIX_Discharge pipe 2 temperature	°C / °F	0-Analog Input	(OU[1..12] × 20) + 10000 + 12
OUIX_Crankcase temperature 1	°C / °F	0-Analog Input	(OU[1..12] × 20) + 10000 + 13
OUIX_Crankcase temperature 2	°C / °F	0-Analog Input	(OU[1..12] × 20) + 10000 + 14
OUIX_Compressor current 1	Amperes	0-Analog Input	(OU[1..12] × 20) + 10000 + 15
OUIX_Compressor current 2	Amperes	0-Analog Input	(OU[1..12] × 20) + 10000 + 16
OUIX_High pressure	MPa	0-Analog Input	(OU[1..12] × 20) + 10000 + 17
OUIX_Low pressure	MPa	0-Analog Input	(OU[1..12] × 20) + 10000 + 18

Table 10. Indoor units

Object name	Possible values	Type	Object instance
IUIX_Communication Status_S	0: No Error 1: Error	3-Binary Input	(IU[1..128] × 25) + 0
IUIX_On/Off_S	0: Off 1: On	3-Binary Input	(IU[1..128] × 25) + 1
IUIX_On/Off_C	0: Off 1: On	4-Binary Output	(IU[1..128] × 25) + 0
IUIX_Operation Mode_S	1: Heat 2: Cool 3: Fan 4: Dry 5: Auto	13-Multistate Input	(IU[1..128] × 25) + 0
IUIX_Operation Mode_C	1: Heat 2: Cool 3: Fan 4: Dry 5: Auto	14-Multistate Output	(IU[1..128] × 25) + 0
IUIX_Temperature Setpoint_S	°C / °F	0-Analog Input	(IU[1..128] × 25) + 0
IUIX_Temperature Setpoint_C	°C / °F	1-Analog Output	(IU[1..128] × 25) + 0
IUIX_FanSpeed_S	1: Low 2: Medium 3: High 4: Powerful	13-Multistate Input	(IU[1..128] × 25) + 1
IUIX_FanSpeed_C	1: Low 2: Medium 3: High 4: Powerful	14-Multistate Output	(IU[1..128] × 25) + 1
IUIX_Remote Lock_S	0: Unlock 1: Lock	3-Binary Input	(IU[1..128] × 25) + 2
IUIX_Remote Lock_C	0: Unlock 1: Lock	4-Binary Output	(IU[1..128] × 25) + 1
IUIX_Louver / Vane Position_S	1: Swing 2: Pos1 3: Pos2 4: Pos3 5: Pos4	13-Multistate Input	(IU[1..128] × 25) + 2

IUXX_Louver / Vane Position_C	1: Swing 2: Pos1 3: Pos2 4: Pos3 5: Pos4	14-Multistate Output	(IU[1..128] × 25) + 2
IUXX_Room Temperature_S	°C / °F	0-Analog Input	(IU[1..128] × 25) + 1
IUXX_Filter Sign_S	0: Off 1: On	3-Binary Input	(IU[1..128] × 25) + 3
IUXX_Unit Error code_S	0: No Error 1 .. 255: Error	0-Analog Input	(IU[1..128] × 25) + 2
IUXX_Compressor_S	0: Off 1: On	3-Binary Input	(IU[1..128] × 25) + 4
IUXX_Filter Sign Reset_C	0: No reset 1: Reset	4-Binary Output	(IU[1..128] × 25) + 2
IUXX_RC Error Reset_C	0: No reset 1: Reset	4-Binary Output	(IU[1..128] × 25) + 3
IUXX_Thermo On/Off_S	0: Off 1: On	3-Binary Input	(IU[1..128] × 25) + 5
IUXX_Expansion valve opening pulse_S	000 .. 999	0-Analog Input	(IU[1..128] × 25) + 3
IUXX_Decision frequency_S	0 .. 255 Hz	0-Analog Input	(IU[1..128] × 25) + 4
IUXX_Demand frequency_S	0 .. 255 Hz	0-Analog Input	(IU[1..128] × 25) + 5
IUXX_Heat Exchange low 1 temperature_S	°C / °F	0-Analog Input	(IU[1..128] × 25) + 6
IUXX_Heat Exchange low 2 temperature_S	°C / °F	0-Analog Input	(IU[1..128] × 25) + 7
IUXX_Heat Exchange low 3 temperature_S	°C / °F	0-Analog Input	(IU[1..128] × 25) + 8
IUXX_Consumption Yesterday_S	Wh/KWh	0-Analog Input	(IU[1..128] × 25) + 9
IUXX_Consumption Today_S	Wh/KWh	0-Analog Input	(IU[1..128] × 25) + 10
IUXX_Consumption Total_S	Wh/KWh	0-Analog Input	(IU[1..128] × 25) + 11
IUXX_Consumption Yesterday Heat_S	Wh/KWh	0-Analog Input	(IU[1..128] × 25) + 12
IUXX_Consumption Today Heat_S	Wh/KWh	0-Analog Input	(IU[1..128] × 25) + 13
IUXX_Consumption Total Heat_S	Wh/KWh	0-Analog Input	(IU[1..128] × 25) + 14
IUXX_Consumption Yesterday Cool_S	Wh/KWh	0-Analog Input	(IU[1..128] × 25) + 15
IUXX_Consumption Today Cool_S	Wh/KWh	0-Analog Input	(IU[1..128] × 25) + 16
IUXX_Consumption Today Cool_S	Wh/KWh	0-Analog Input	(IU[1..128] × 25) + 17

## 6.4. Integration into Home Automation Systems

### 6.4.1. Home Automation Signals

The following tables list all available Home Automation signals for this gateway.



#### NOTE

- **SET:** Command used to control the indoor unit. It is sent by the client.
- **CHN:** Command used to get notifications of changes in the status of a specific function of the gateway. It is sent spontaneously by the gateway itself.
- **GET:** Command used to get the status of a specific function. It is sent by the client.

To know more about the Home Automation protocol, see the [Protocol Specifications Manual](#).

Table 11. Indoor units signals

Name	Possible values	acNum <sup>1</sup>	Commands supported
On/Off	ON OFF	See the note below	SET/CHN/GET
Operation Mode	HEAT COOL FAN DRY AUTO		SET/CHN/GET
Fan Speed	1 2 3 4		SET/CHN/GET
Vane Position	1 2 3 4 SWING		SET/CHN/GET
Temperature Setpoint (x10)	Celsius: 16 .. 30°C Fahrenheit: 61 .. 86°F		SET/CHN/GET
AC Ambient Temperature (x10)	Celsius: 0 .. 30°C Fahrenheit: 32 .. 86°F		CHN/GET
Unit Error code	0: No Error X: Error		CHN/GET
Error IU	OK ERR		CHN/GET



#### NOTE

<sup>1</sup> This index must be set according to the Unit ID Index.

For outdoor units, the acNum value must be the same as the minimum indoor unit associated in the CONFIGURATION section.

## 7. Late Configuration: Change the Gateway's Protocol

Reconfiguring the gateway with a different protocol is very easy:

1. Connect the gateway to the PC and open the configuration tool Intesis MAPS.
2. Select the new template you need.
3. Click **Next** or double-click the template in the list.
4. A message will pop up, asking if you want to save the project currently loaded in the gateway.
5. Click **Yes** or **No**, depending on your needs.
6. Configure the needed parameters and signals for your new project.
7. Send the configuration to the gateway.



### NOTE

For a complete gateway configuration guide, please refer to the [Intesis MAPS Configuration Guide for IN776MHI\\*\\*\\*O000](#).

## 8. Error Codes



### NOTE

These error codes are the same for all applications.

Error code	Code in the wired RC	Description
0	N/A	No active error
1	E1	Remote controller communication error
2	E2	Duplicated indoor unit address
3	E3	Outdoor unit signal line error
5	E5	Communication error during operation
6	E6	Indoor heat exchanger temperature thermistor anomaly
7	E7	Indoor return air temperature thermistor anomaly
8	E8	Heating overload operation
9	E9	Drain trouble
10	E10	Excessive number of indoor units (more than 17) by controlling one remote controller
12	E12	Address setting error by mixed setting method
14	E14	Communication error between master and slave indoor units
15	E15	I/U Supply Air sensor disconnection
16	E16	Indoor fan motor anomaly
19	E19	Indoor unit operation check, drain motor check setting error
28	E28	Remote controller temperature thermistor anomaly
30	E30	Unmatched connection of indoor and outdoor unit
31	E31	Duplicated outdoor unit address No.
32	E32	Open L3 Phase on power supply at primary side
33	E33	Inverter primary current error
35	E35	Cooling overload operation
36	E36	Discharge pipe temperature error
37	E37	Outdoor heat exchanger temperature thermistor anomaly
38	E38	Outdoor/Ambient air temperature thermistor anomaly
39	E39	Discharge pipe temperature thermistor anomaly
40	E40	High pressure error
41	E41	Power transistor overheat
42	E42	Current cut
43	E43	Excessive number of indoor units connected, excessive total capacity of connection
45	E45	Communication error between inverter PCB and outdoor control PCB
46	E46	Mixed address setting methods coexistent in same network
47	E47	Inverter overcurrent error
48	E48	Outdoor DC fan motor anomaly
49	E49	Low pressure anomaly
51	E51	Inverter anomaly
53	E53	Suction pipe temperature thermistor anomaly
54	E54	High/Low pressure sensor anomaly
55	E55	Underneath temperature thermistor anomaly
56	E56	Power transistor temperature thermistor anomaly
57	E57	Insufficient in refrigerant amount or detection of service valve closure

Error code	Code in the wired RC	Description
58	E58	Anomalous compressor by loss of synchronism
59	E59	Compressor startup failure
60	E60	Rotor position detection failure / Anomalous compressor rotor lock
61	E61	Communication error between the master unit and slave units
63	E63	Emergency stop

**IMPORTANT**

These error codes may differ depending on the specific AC unit model.

**NOTE**

If you detect a non-listed error code, please contact Mitsubishi Heavy Industries technical support.